

LAMINAR CONVECTIVE HEAT TRANSFER AND FRICTION FACTOR OF Al_2O_3 NANOFLUID IN CIRCULAR TUBE FITTED WITH TWISTED TAPE INSERTS

L. Syam Sundar² and K.V. Sharma^{1,2}

¹Faculty of Mechanical Engineering
Universiti Malaysia Pahang
26600 Pekan, Pahang, Malaysia
Tel./Fax. +6-09-4242324/+6-09-4242202
E-mail: kvsharmajntu@gmail.com

²Centre for Energy Studies
JNTUH College of Engineering
Kukatpally, Hyderabad 500085, India,
Tel./Fax. +91-40-32408715/+91-40-23058720

ABSTRACT

We experimentally investigated the fully developed laminar convective heat transfer and friction factor characteristics of different volume concentrations of Al_2O_3 nanofluid in a plain tube and fitted with different twist ratios of twisted tape inserts. Experiments were conducted with water and nanofluid in the range of $700 < Re < 2200$, particle volume concentration of $0 < \phi < 0.5\%$, and twisted tape twist ratios of $0 < H/D < 15$. The nanofluid heat transfer coefficient is high compared to water and further heat transfer enhancement is observed with twisted tape inserts. The pressure drop increases slightly with the inserts, but is comparatively negligible. A generalized regression equation is developed based on the experimental data for the estimation of the Nusselt number and friction factor for water and nanofluid in a plain tube and with twisted tape inserts.

Keywords: Forced convection in a tube, aluminium oxide nanofluid, twisted tape inserts, heat transfer enhancement, nanofluid friction factor.

INTRODUCTION

Low thermal conductivity of conventional heat transfer fluids such as water, oil and ethylene glycol is a serious limitation for improving the performance and compactness of many engineering equipments such as heat exchangers. Initial experiments with small sized metallic particles possessing high thermal conductivity are used to enhance heat transfer. The early research with the suspension of these micrometer sized particles caused problems associated with dispersion and flow. To overcome this, nano-sized particles are developed, dispersed in a base liquid, and thermal conductivity enhancement is obtained (Choi, 1995). Thermo-physical properties of different volume concentrations of nanofluid are explained (Masuda et al., 1993; Pak and Cho, 1998; Lee et al., 1999; Wang et al., 1999; Eastman et al., 1999; Eastman et al., 2001; Das et al., 2003).

The enhancement of thermal conductivity is confirmed by Pak and Cho (1998) and Xuan and Li (2003) using Al_2O_3 , TiO_2 and Cu nanoparticles dispersed in water. They also estimated heat transfer coefficients and pressure drop under turbulent flow in

tubes with nanofluids at different concentrations. The heat transfer coefficients are observed to increase with concentration compared to base liquid water. The authors presented regression equations for the estimation of Nusselt numbers. Numerical studies are undertaken (Namburu et al., 2009) with CuO, Al₂O₃ and SiO₂ nanofluids under turbulent flow and higher heat transfer coefficients are obtained compared to water.

Experimentally, Wen and Ding (2004) observed that Al₂O₃ nanoparticles dispersed in water show enhancements in laminar convective heat transfer coefficients. Experiments conducted by Heris et al. (2007) with Al₂O₃/water nanofluid in the laminar flow range of the Reynolds number subject to an isothermal wall boundary condition predict higher values of heat transfer. The enhancements are found to increase with the Reynolds number, as well as particle concentration. Numerical studies were undertaken by Maiga et al. (2005) in the laminar range with Al₂O₃/water Al₂O₃/ethylene glycol nanofluids and they obtained a heat transfer enhancement with nanofluid. Numerical analysis of laminar flow heat transfer of Al₂O₃ /ethylene glycol and Al₂O₃/ water nanofluids in tube has been reported (Palm et al., 2004; Roy et al., 2004) and wall shear stress is observed to increase with volume concentration and the Reynolds number. Heat transfer enhancements with flow of nanofluids in a tube are summarized (Kakaç and Pramuanjaroenkij, 2009; Wang and Majumdar, 2007). Passive enhancement of heat transfer can also be achieved with the use of twisted tape inserts for flow in a tube or duct. Heat transfer enhancements are obtained through experiments and numerical analysis of the flow of single phase fluids in a tube, and are valid for a wide range of Reynolds numbers (Smithberg and Landis, 1964; Lopina and Bergles, 1969; Lecjaks et al., 1987; Sarma et al., 2003).

Experimental determination of heat transfer is achieved using twisted tape inserts in a tube with Al₂O₃ nanofluid at different volume concentrations (Sharma et al., 2009; Sundar and Sharma, 2010). These authors have presented empirical correlations for the estimation of the Nusselt number and friction factor in the transition and turbulent flow range. The equation they propose has the flexibility to estimate the Nusselt number for the flow of water or nanofluid in a plain tube and with twisted tape. Nanofluid heat transfer and pressure drop in the laminar Reynolds number range with twisted tape insert have not been estimated. Experimental determination of these parameters is undertaken in the present study.

EXPERIMENTAL SETUP AND PROCEDURE

The schematic diagram of the experimental setup is shown in Figure 1a. The fluid flows through a copper tube of 0.012 m dia, a chiller or collecting tank, and a storage tank with the aid of a pump. The copper tube is heated uniformly by wrapping it with two nichrome heaters of 20 gauge, having a resistance of 53.5Ω per meter length and 1000 W maximum rating, and the entire test section is subject to a constant heat flux boundary condition. The space between the test section and the outer casing is stuffed with rock wool insulation to minimize heat loss to the atmosphere. The test section of 1.5 m in length is provided with five K-type thermocouples, three brazed to the surface at distances of 0.375, 0.75, 1.125 m from entry and two located to measure the working fluid inlet and outlet temperatures. All these thermocouples have 0.1° C resolution and are calibrated before fixing them at the specified locations. The aspect ratio of the test section is sufficiently large for the flow to be hydro-dynamically developed. The fluid is forced through the test section with the aid of a pump, the suction side connected to a storage tank. The storage tank, made of stainless steel, is of 30 litres capacity. The

liquid which is heated in the test section is allowed to cool by passing it through a chiller. The liquid then flows to the storage tank by gravity. The provision of the chiller helps to achieve the steady state condition faster.

The twisted tapes are made in the laboratory from a 1mm thick and 0.01 m radius of aluminium strip, as shown in Figure 1b, and the dimensions of the twisted tape inserts are shown in Table 1. The two ends of a strip were held on a lathe, one at the headstock end and the other at the tail stock end, by special devices made in the laboratory. The strip was then subjected to twist by turning the chuck manually. Four twist ratios of $H/D = 5, 10$ and 15 were made. Twisted tapes are tightly fitted into the tube and the tape fin effect is neglected.

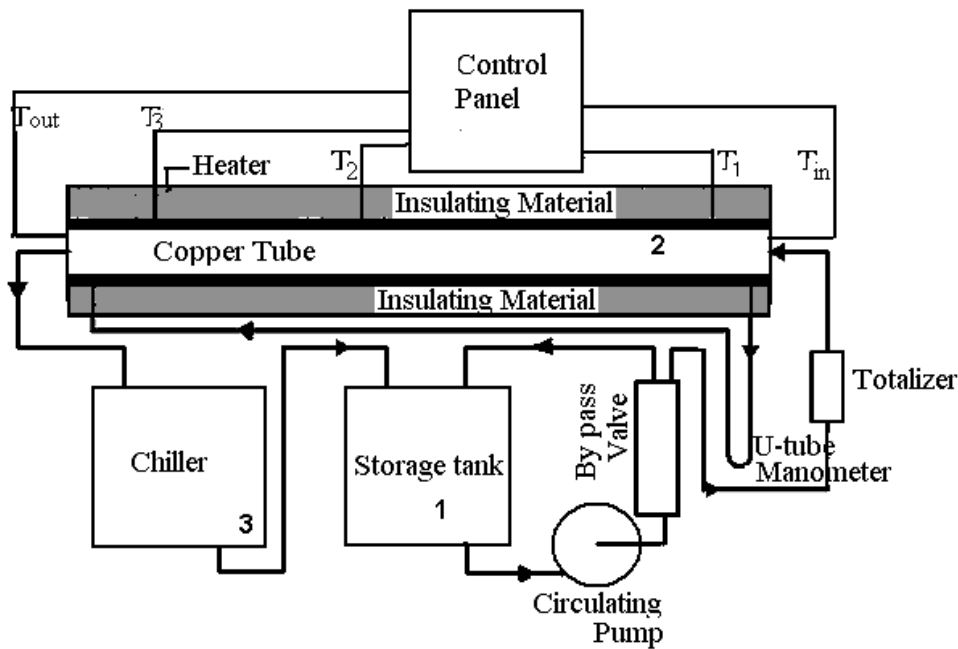

Figure 1a. Schematic diagram of the experimental setup

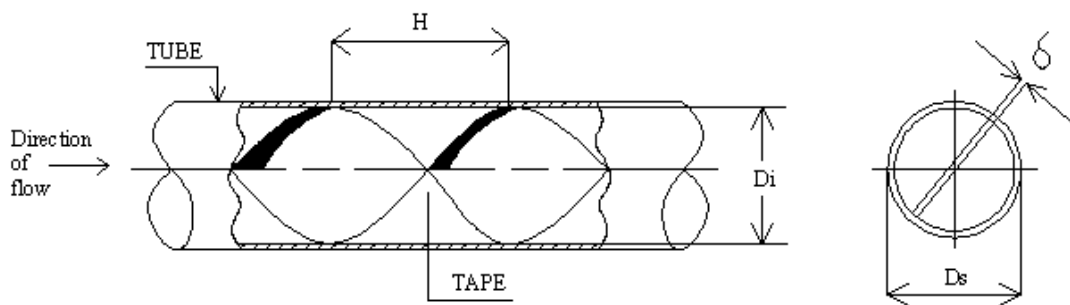

Figure 1b. Full-length twisted tape insert inside a tube

Table 1. Dimensions of twisted tape insert

S. No.	Parameter	Twist Ratio, H/D, m		
		5	10	15
1	H (Width)	0.05	0.1	0.15
2	D (Diameter)	0.01	0.01	0.01

After the experimental setup is assembled, the storage tank is filled with the working fluid. Experiments are conducted with water and nanofluids to determine the friction factor and heat transfer coefficients for flow in a tube. The procedure for preparation of nanofluids follows Sundar et al. (2007). Nanofluid at different volume concentrations of 0.02, 0.1 and 0.5% are used in conducting the experiments. The working fluid flow rate in the test section is evaluated from the flow meter readings and validated manually. The properties of the fluid are evaluated at the mean temperature, as explained by Sundar and Sharma (2008). The required data for the estimation of heat transfer coefficients and friction factor are recorded at different flow Reynolds number range of 700-2200 with flow of water and nanofluid in a tube. A similar procedure is adopted for flow with longitudinal strip inserts and relevant comparisons are made. The heat transfer coefficient is estimated with Newton's law of cooling.

RESULTS AND DISCUSSION

Nusselt Number of Water and Nanofluid in Plain Tube

The balance between the energy supplied by heating and energy absorbed by the flowing liquid is established using Eqns. (1) and (2) for every set of data and the experimental heat transfer coefficient is estimated with Eq. (3).

$$Q = V \times I \quad (\text{Energy supplied}) \quad (1)$$

$$Q = m \times C \times (T_0 - T_i) \quad (\text{Energy absorbed}) \quad (2)$$

$$h_{Exp} = \frac{Q}{A(T_{wall} - T_{mean})}, \quad A = \Pi D_i L, \quad Nu_{Exp} = \frac{h D_i}{k} \quad (3)$$

The deviation between the values obtained with Eqns. (1) and (2) is less than $\pm 2.5\%$ and the heat loss to atmosphere is neglected. The experimental Nusselt number of fully developed laminar flow with different volume concentrations of nanofluid is shown in Figure 2, along with the data of water. From the figure it is observed that the Nusselt number increases with the increase of volume concentration under the same Reynolds number nanofluid. The reason for the heat transfer enhancement for nanofluid is the effect of thermo-physical properties. Comparatively, the thermo-physical properties are greater for nanofluid.

The equation for the estimation of the Nusselt number for different volume concentrations of Al_2O_3 nanofluid in a plain tube under fully developed laminar flow is obtained with an average deviation (AD) of 2.46% and standard deviation (SD) of 3.23% given by

$$Nu_{Reg} = 0.2624 Re^{0.5860} Pr^{0.3} (0.001 + \varphi)^{0.07094} \quad (4)$$

Valid in the range $700 < Re < 2200, 0 < \varphi < 0.5\%$

The values estimated from Eq. (4) are shown in Figure 3, along with the experimental Nusselt number of water and nanofluid.

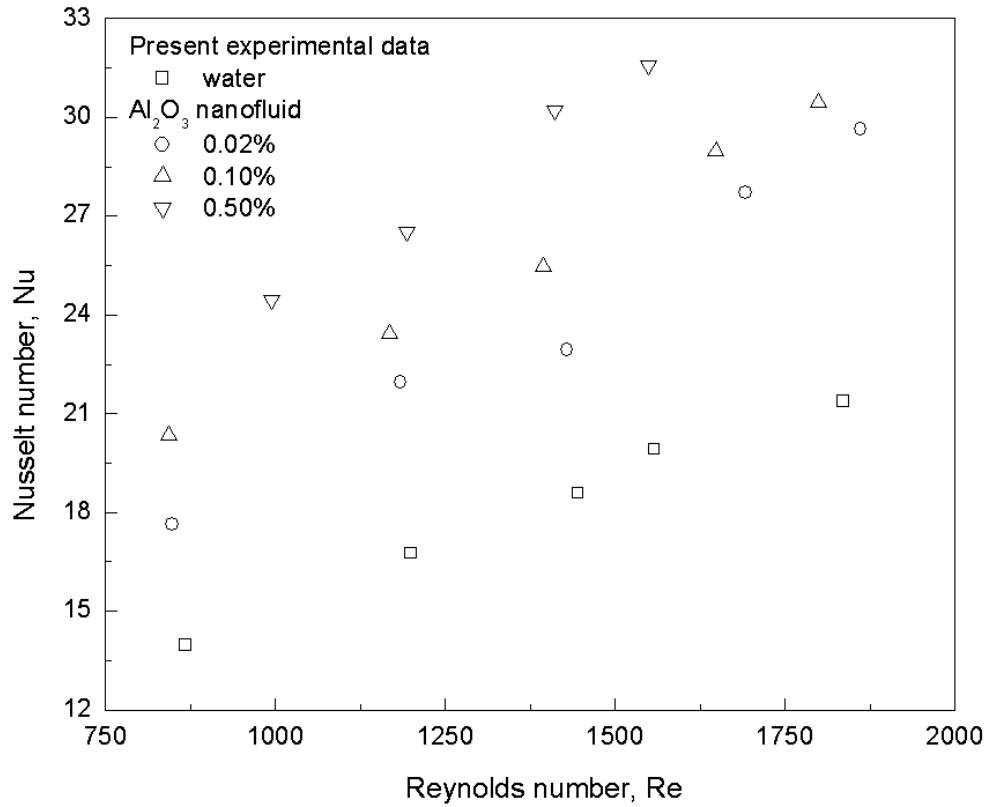

Figure 2. Experimental Nusselt number water and different volume concentrations of nanofluids

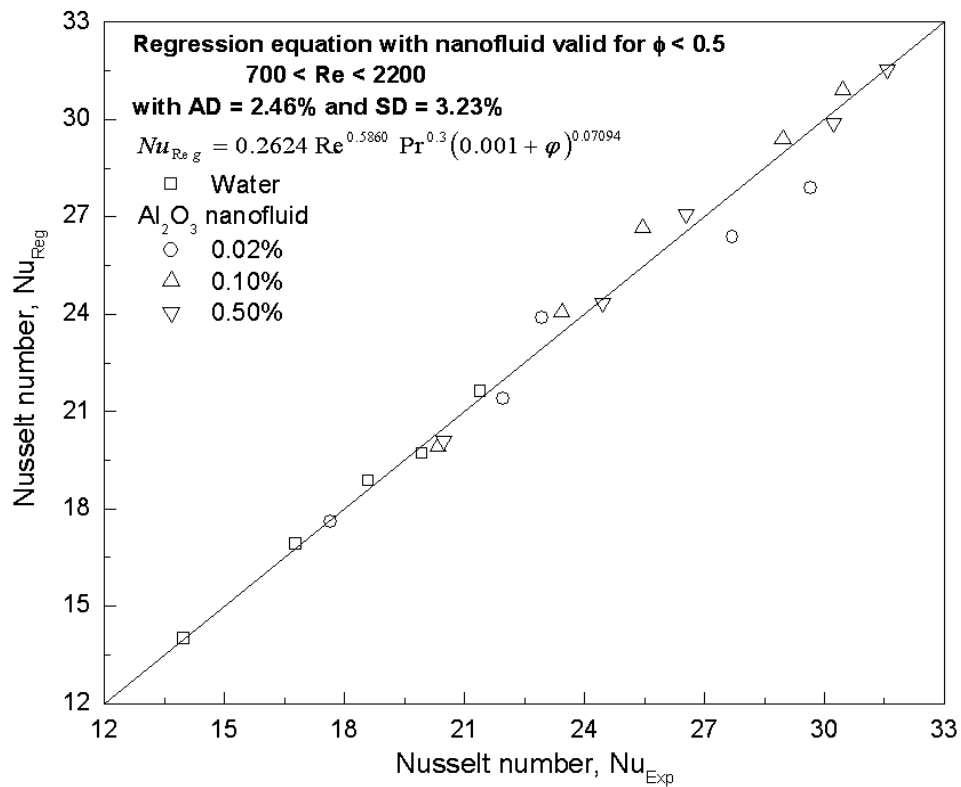

Figure 3. Experimental Nusselt number compared with Eq. (4).

Nusselt Number of Water and Nanofluid in Plain Tube with Twisted Tape Inserts

Experiments with twisted tape inserts are conducted with water and nanofluid following the procedure explained earlier for flow in a tube. The procedure is repeated with tapes of different twist ratios of 5, 10 and 15. The equation (Sarma et al., 2003) is based on theoretical analysis and obtained with a standard deviation of 4%, and the average deviation of 3% for the estimation of Nusselt number is given by

$$Nu_{Reg} = 0.2036 Re^{0.55} Pr^{0.3} \left(1.0 + \frac{D}{H}\right)^{4.12} \quad (5)$$

valid in the range $100 < Re < 3000$, $5 < Pr < 400$, $2.5 < H/D < 10$ for pure liquids.

The experimental Nusselt number of water and nanofluid for flow in a tube and with twisted tape inserts is presented in Figure 4. However, no literature is available for comparison. From the Figure it can be observed that higher heat transfer rates are obtained with twisted tape inserts than with nanofluid flow in a tube. The experimental Nusselt number of water and nanofluid in a plain tube with different twist ratios of twisted tape inserts is shown in Figure 5.

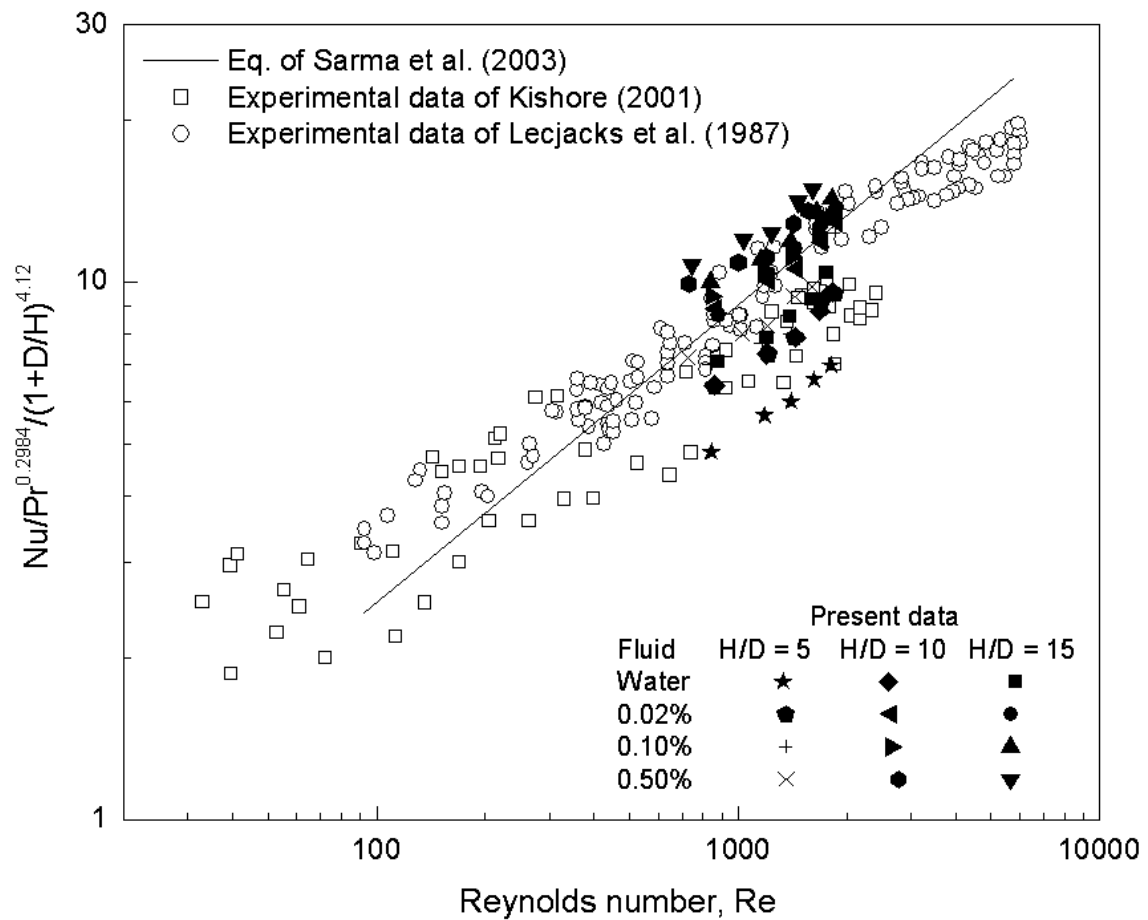

Figure 4. Comparison of present experimental data of water and nanofluid with twisted tape inserts with the data available in the literature

Hence, the present data for flow of water and Al₂O₃ nanofluid in a tube and with twisted tape insert is subjected to regression and the equation is obtained with an average deviation (AD) of 4.14% and standard deviation (SD) of 5.23%, given by

$$Nu_{Reg} = 0.5652 Re^{0.5004} Pr^{0.3} (0.001 + \phi)^{0.07060} \left(0.001 + \frac{D}{H} \right)^{0.02395} \quad (6)$$

valid in the range $700 < Re < 2200$, $0 < \phi < 0.5\%$, $4.4 < Pr < 6.5$, $0 < H/D < 15$. ($\phi = 0$ for water, $H/D = 0$ for plain tube). The values of Nusselt estimated with Eq. (6) are in good agreement with the experimental values shown in Figure 6, thus validating the regression equation developed.

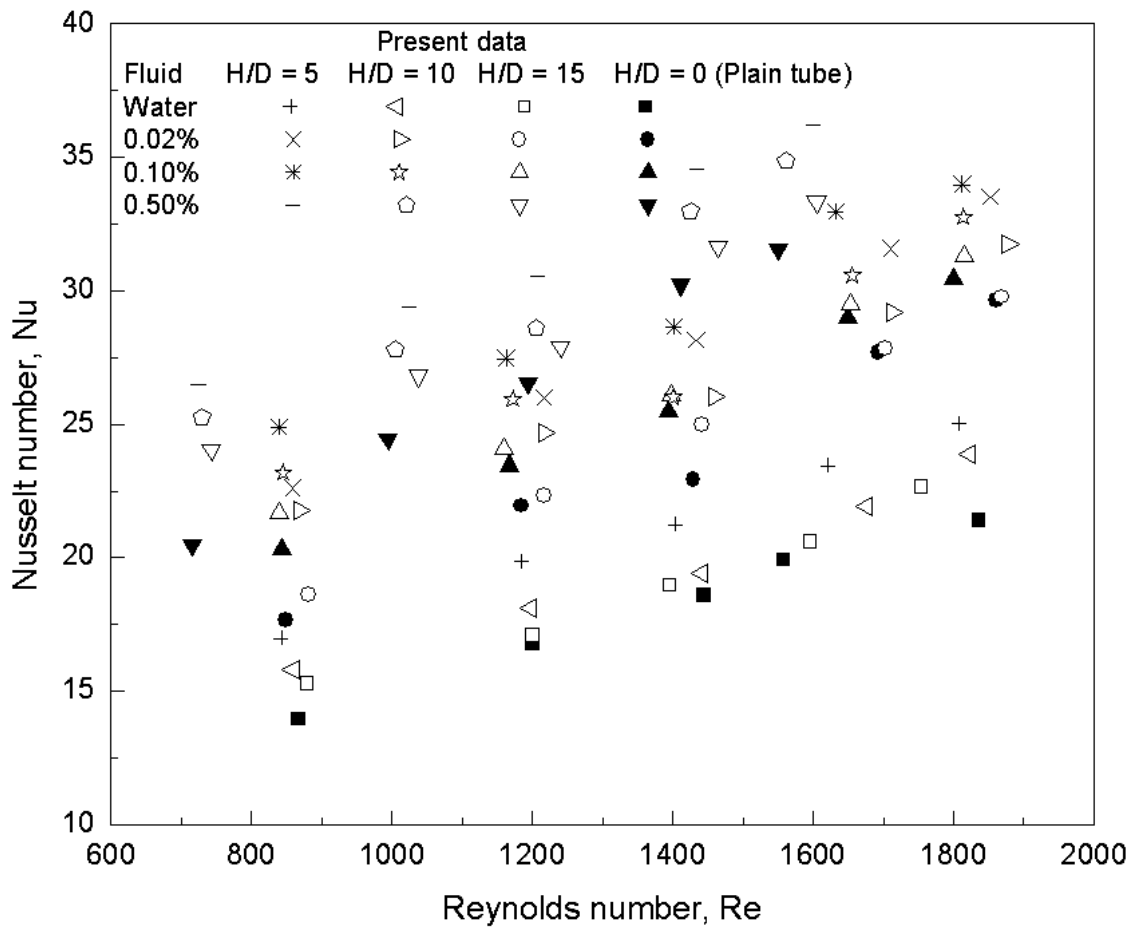

Figure 5. Experimental Nusselt number of water and nanofluid in plain tube with twisted tape inserts

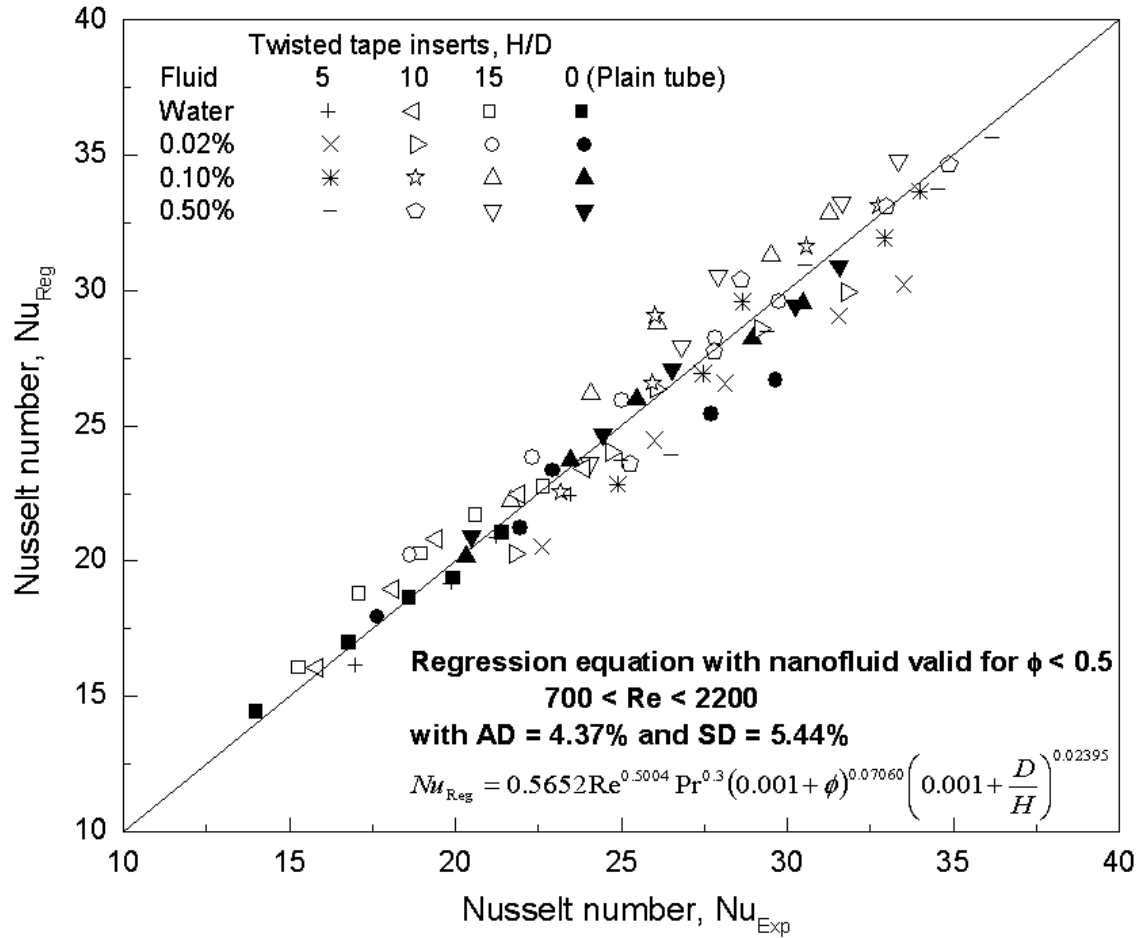

Figure 6. Comparison of experimental Nusselt number with Eq. (6)

Friction Factor of Water and Nanofluid in a Plain Tube

The friction factor can be determined from the relation

$$f = \frac{\Delta P}{\left(\frac{L}{D}\right)\left(\frac{\rho V^2}{2}\right)} \quad (7)$$

The single-phase fluid friction factor (Moody, 1944) is

$$f = \frac{64}{Re} \quad (8)$$

The experimental friction factor of water and different volume concentrations of nanofluid estimated from Eq. (7) are compared with the values estimated from Eq. (8) and shown in Figure 7. It is evident that the friction factor values for nanofluid fall on the same values as water, which means that with the addition of solid particles in the base fluid there is not much enhancement of the friction factor.

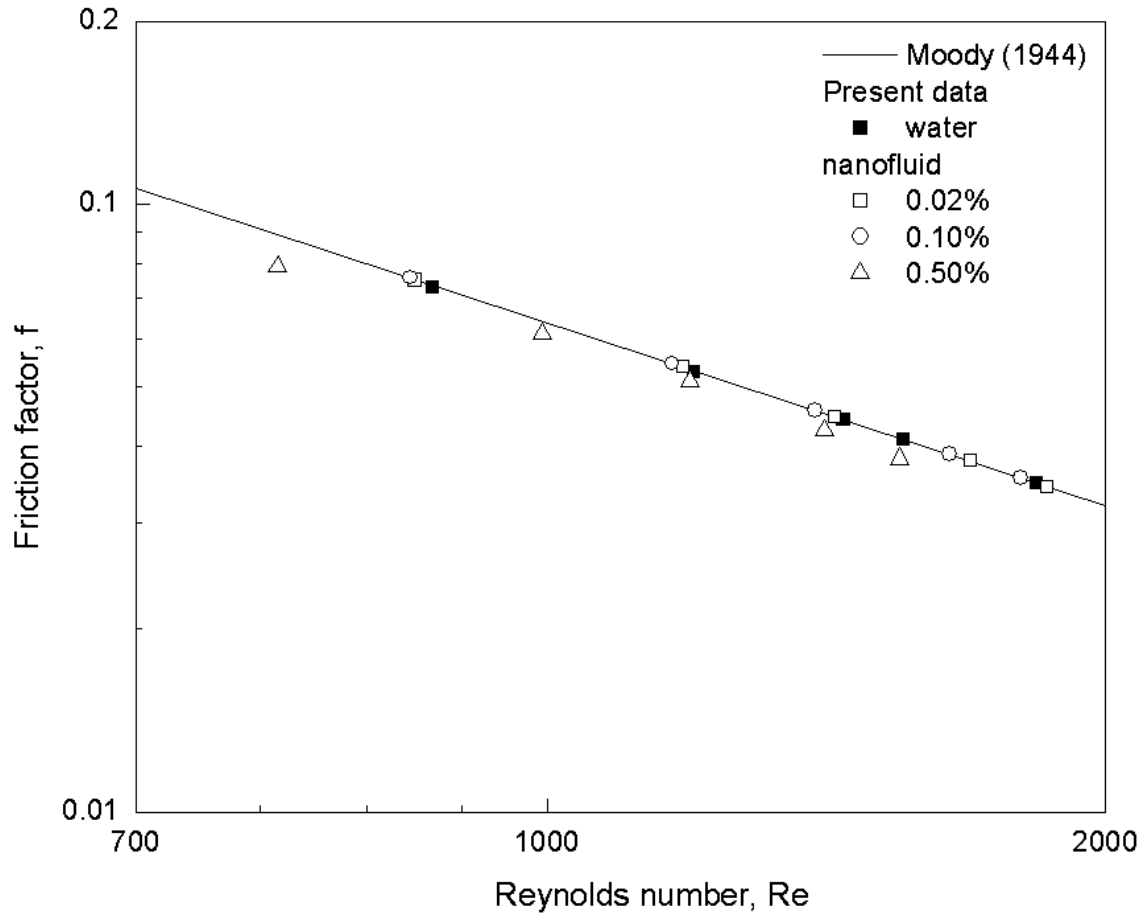

Figure 7. Comparison of experimental friction factor in plain tube with Moody’s (1944) equation.

A generalized regression equation is developed for the estimation of the friction factor of water and different volume concentrations of nanofluid in a plain tube under a fully developed laminar flow condition with an average deviation (AD) of 4.552% and standard deviation (SD) of 5.799% given by

$$f_{Re_g} = 39.54 Re^{-0.9316} (0.001 + \varphi)^{0.01} \quad (9)$$

valid for $700 < Re < 2200$, $4.4 < Pr < 6.5$, $0 < \varphi < 0.5$.

The values of the friction factor estimated with Eq. (9) are in good agreement with the experimental values, as shown in Figure 8, thus validating the equation developed.

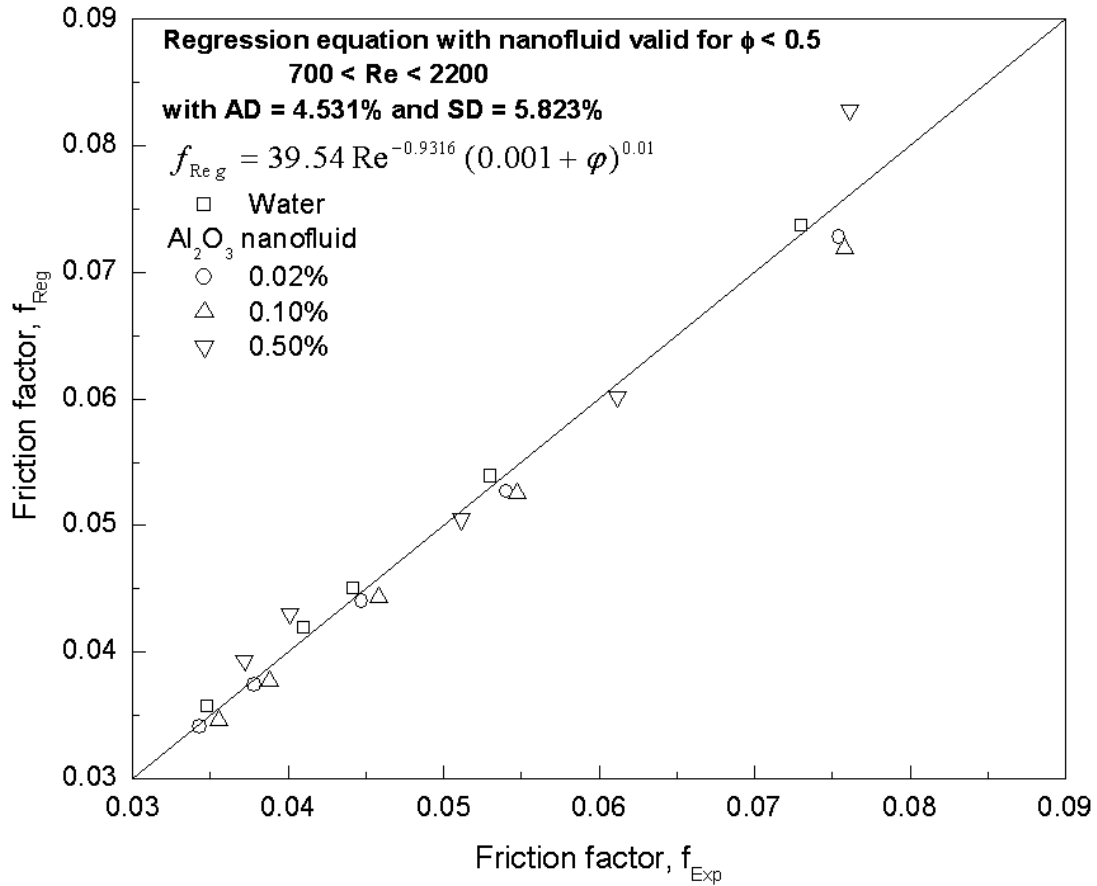

Figure 8. Comparison of experimental friction factor with Eq. (9).

Friction Factor of Water and Nanofluid with and without Twisted Tape Inserts

Eq. (7) is used to estimate the experimental friction factor of water and nanofluid in a plain tube with twisted tape inserts and the data is represented in Figure 9. However, no literature is available for comparison. It is evident that higher friction factors are obtained with twisted tape inserts than with flow in a tube for either water or nanofluid.

The present data on the friction factor are subjected to regression and obtained with an average deviation (AD) of 4.886% and standard deviation (SD) of 6.221% given by

$$f_{Reg} = 52.08 Re^{-0.9641} (0.001 + \phi)^{0.01} \left(0.001 + \frac{D}{H} \right)^{0.006120} \quad (10)$$

valid for the range $700 \leq Re \leq 2200$, $4.4 \leq Pr \leq 5.5$, $0 \leq \phi \leq 0.5$, $0 \leq (H/D) \leq 15$ ($\phi = 0$ for water, $H/D = 0$ for plain tube). The values of the friction factor estimated with Eq. (10) are in good agreement with the experimental values, as shown in Figure 10, thus validating the equation developed.

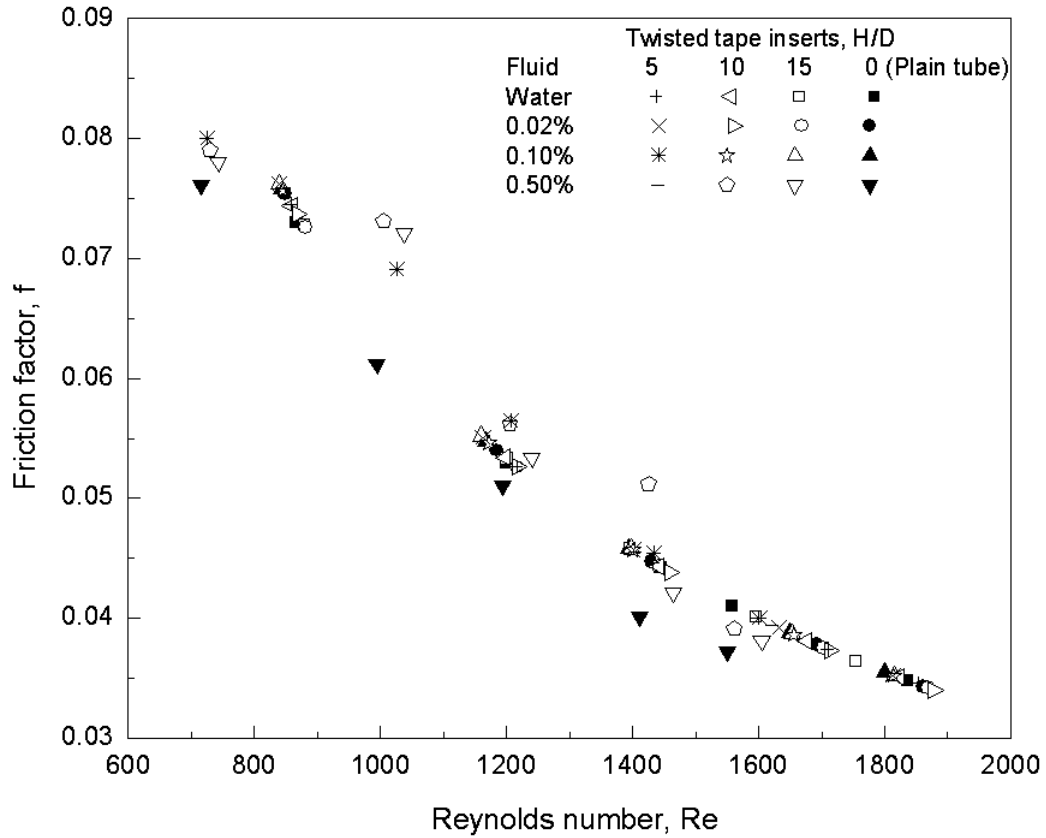

Figure 9. Friction factor of water and nanofluid in a plain tube with twisted tape inserts.

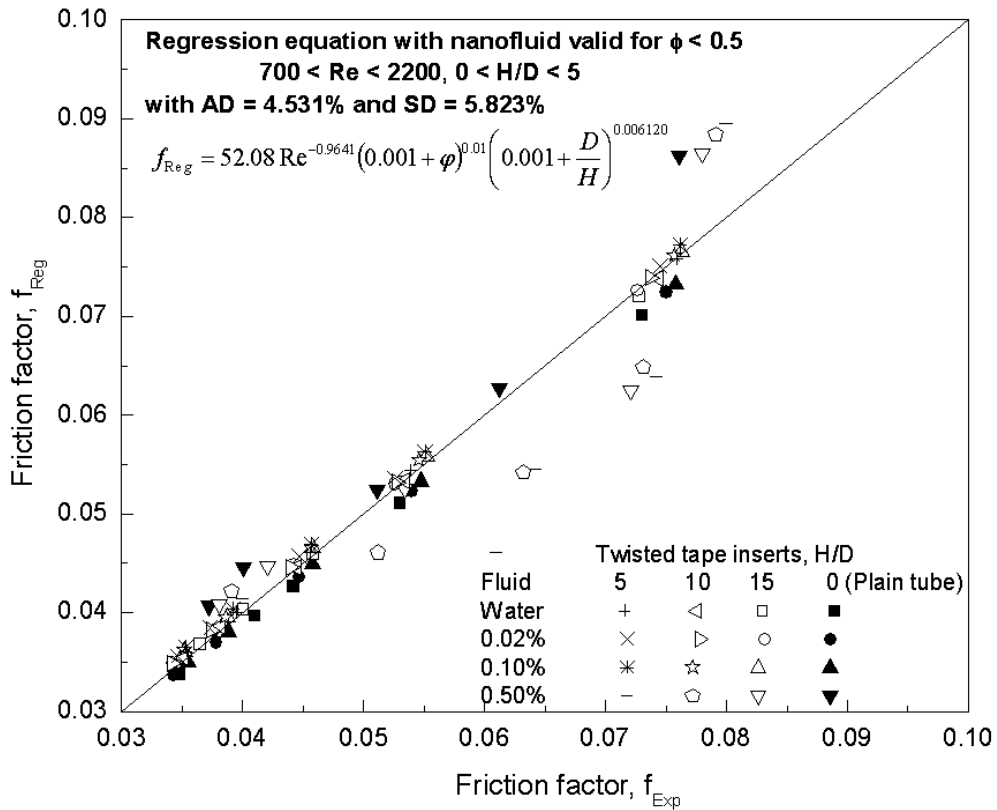

Figure 10. Comparison of experimental friction factor with Eq. (10)

CONCLUSIONS

The enhancement in heat transfer in a plain tube with 0.5% volume concentration Al_2O_3 nanofluid when compared to water is 46.52% and 47.59% for Reynolds numbers of 700 and 2200 respectively. The enhancement of the friction factor in a plain tube with 0.5% volume concentration Al_2O_3 nanofluid compared to water is 1.042 times and 1.068 times for Reynolds numbers of 700 and 2200 respectively. The heat transfer coefficient of 0.5% volume concentration Al_2O_3 nanofluid with twisted tape insert having $(H/D) = 5$ is 14.60% and 29.50% greater at Reynolds numbers of 700 and 2200 respectively compared to the same fluid, and 69.14% and 89.76% greater than water flowing in a plain tube. The friction factor of 0.5% volume concentration Al_2O_3 nanofluid with twisted tape insert having $(H/D) = 5$ is 1.0958 times greater at a 700 Reynolds number and 1.0652 times at a 2200 Reynolds number compared to water, and 1.512 times and 1.0412 times compared to the same fluid flowing in a tube. The use of twisted tape inserts is advantageous at higher Reynolds numbers based on the values of the friction factor and heat transfer compared to flow in a tube either for water or nanofluid. The use of nanofluid enhances the heat transfer coefficient with no significant enhancement in pressure drop compared to water in the range tested. The experimental data of friction and the Nusselt number of water and Al_2O_3 nanofluid for flow in a plain tube and with longitudinal strip insert can be presented respectively as

$$f_{Reg} = 52.08 \text{ Re}^{-0.9641} (0.001 + \phi)^{0.01} \left(0.001 + \frac{D}{H} \right)^{0.006120}$$

$$Nu_{Reg} = 0.5652 \text{ Re}^{0.5004} \text{ Pr}^{0.3} (0.001 + \phi)^{0.07060} \left(0.001 + \frac{D}{H} \right)^{0.02395}$$

REFERENCES

- Choi, S.U.S. 1995. Enhancing thermal conductivity of fluid with nanoparticles. In: Siginer, D.A., Wang, H.P. (eds.) *Developments and Applications of Non-Newtonian Flows*, FED-V.231/ MD-V.66. ASME, pp. 99-105.
- Das, S.K, Putra, N., Thiesen, P. and Roetzel, W. 2003. Temperature dependence of thermal conductivity enhancement for nanofluids. *Journal of Heat Transfer*, 125: 567-574.
- Eastman, J.A., Choi, S.U.S., Li, S., Soyez, G., Thompson, L.J. and DiMelfi, R.J. 1999. Novel thermal properties of nanostructured materials. *Journal of Metastable Nanocrystal Materials*, 2(6): 629-634.
- Eastman, J.A., Choi, S.U.S., Li, S., Yu, W. and Thompson, L.J. 2001. Anomalously increased effective thermal conductivities of ethylene glycol-based nanofluids containing copper nanoparticles. *Applied Physics Letter*, 78(6): 718-720.
- Heris, S.Z., Esfahany, M.N. and Etemad, S.G. 2007. Experimental investigation of convective heat transfer of Al_2O_3 /water nanofluid in circular tube. *International Journal of Heat and Fluid Flow*, 28: 203-210.

- Kakaç, S. and Pramuanjaroenkij, A. 2009. Review of convective heat transfer enhancement with nanofluids. *International Journal of Heat and Mass Transfer*, 52: 3187-3196.
- Kishore, P.S. 2001. *Experimental and theoretical studies of convective momentum and heat transfer in tubes with twisted tape inserts*. PhD Thesis, Andhra University, India.
- Lecjaks, Z., Machac, I. and Sir, J. 1987. Heat transfer to a Newtonian liquid flowing through a tube with an internal helical element. *International Chemical Engineering*, 27: 210-217.
- Lee, S., Choi, S.U.S., Li, S. and Eastman, J.A. 1999. Measuring thermal conductivity of fluids containing oxide nanoparticles. *Journal of Heat Transfer*, 121: 208-289.
- Lopina, R.F. & Bergles, A.E. 1969. Heat transfer and pressure drop in tape-generated swirl flow of single phase water. *Journal of Heat Transfer*, 91: 434-442.
- Masuda, H., Ebata, A., Teramae, K. and Hishinuma, N. 1993. Alteration of thermal conductivity and viscosity of liquid by dispersing ultra-fine particles (dispersion of γ -Al₂O₃, SiO₂ and TiO₂ ultra-fine particles). *Netsu Bussei* (in Japanese) 4(4): 227-233.
- Moody, L.F. 1944. Friction factor for pipe flow. *Trans. ASME*, 66: 671-684.
- Namburu, P.K., Das, D.K., Tanguturi, K.M. and Vajjha, R.K. 2009. Numerical study of turbulent flow and heat transfer characteristics of nanofluids considering variable properties. *International Journal of Thermal Sciences*, 48(2): 290-302.
- Pak, B.C. and Cho, Y.I. 1998. Hydrodynamic and heat transfer study of dispersed fluids with submicron metallic oxide particles. *Experimental Heat Transfer*, 11, 151-170.
- Palm, S.J., Roy, G. and Nguyen, C.T. 2004. Heat transfer enhancement in radial flow cooling system using nanofluid. In: *Proceedings of the ICHMT Inter. Symp. Advance Comp. Heat Transfer, Norway*, CHT-04-121.
- Roy, G., Nguyen, C.T. and Lajoie, P.R. 2004. Numerical investigation of laminar flow and heat transfer in a radial flow cooling system with the use of nanofluids. *Superlattices and Microstructures*, 35(3): 497-511.
- Sarma, P.K., Subramanyam, T., Kishore, P.S., Dharma Rao, V. and Kakac, S. 2003. Laminar convective heat transfer with twisted tape inserts in a tube. *International Journal of Thermal Sciences*, 42: 821-828.
- Sharma, K.V., Sundar, L.S. and Sarma, P.K. 2009. Estimation of heat transfer coefficient and friction factor in the transition flow with low volume concentration of Al₂O₃ nanofluid flowing in a circular tube and with twisted tape insert. *International Communications in Heat and Mass Transfer*, 36: 503-507.
- Smithberg, E. and Landis, F. 1964. Friction and forced convective heat transfer characteristics in tube with twisted-tape swirl generators. *Journal of Heat Transfer*, 86: 39-49.
- Sundar, L.S., Ramanathan, S., Sharma, K.V. and Sekhar Babu P. 2007. Temperature dependent flow characteristics of Al₂O₃ nanofluid. *International Journal of Nanotechnology and Applications*, 1(2): 35-44.
- Sundar, L.S. and Sharma, K.V. 2008. Thermal conductivity enhancement of nanoparticles in distilled water. *International Journal of Nanoparticles*, 1(1): 66-77.
- Sundar, L.S. and Sharma, K.V. 2010. Turbulent heat transfer and friction factor of Al₂O₃ nanofluid in circular tube with twisted tape inserts. *International Journal of Heat and Mass Transfer*, 53: 1409-1416.

- Wang, X.Q. and Mujumdar, A.S. 2007. Heat transfer characteristics of nanofluids: a review. *International Journal of Thermal Sciences*, 46: 1-19.
- Wang, X., Xu, X. and Choi, S.U.S. 1999. Thermal conductivity of nanoparticles-fluid mixture. *Journal of Thermophysics Heat Transfer*, 13(4): 474-480.
- Wen, D. & Ding, Y. 2004. Experimental investigation into convective heat transfer of nanofluid at the entrance region under laminar flow conditions. *International Journal of Heat and Mass Transfer*, 47(24): 5181-5188.
- Xuan, Y. and Li, Q. 2003. Investigation on convective heat transfer and flow features of nanofluids. *Journal of Heat Transfer*, 125: 151-155.

Nomenclature

A	area, m^2
C	specific heat, J/kg K
D	inner diameter of the tube, m
f	friction factor
h	convective heat transfer coefficient, $W/m^2 K$
I	current, Amp
k	thermal conductivity, W/m K
L	length of the tube, m
\dot{m}	mass flow rate, kg/s
Nu	Nusselt number, hD/k
Pr	Prandtl Number, $\mu C/k$
Re	Reynolds number, $\frac{4\dot{m}}{\pi D \mu}$
T	temperature, $^{\circ}C$
V	voltage, volts
v	velocity, m/sec

Greek symbols

ΔP	pressure drop across the tube
ϕ	volume concentration of nanoparticles, %
μ	dynamic viscosity, $kg/m^2 s$
ρ	density, kg/m^3

Subscripts

Exp	experimental
h	hydraulic diameter
i	inner diameter
m	mean
Reg	regression
W	wall